



---

## ADP SERIES

---

### CHEMDOSE CHEMICAL DOSING PUMPS

---



**Aquatrol ChemDose Chemical Dosing Pumps** are versatile, easy to use and easy to program pumps ideal for chlorine and a wide variety of chemical feed applications.

**Aquatrol ChemDose Chemical Dosing Pumps** are not only reliable, quiet and completely enclosed, the housing is chemical resistant and provides outstanding protection in outdoor or indoor applications. With its durable Teflon diaphragm and PTFE pump head you can rest assured that it will provide years of service with little to no maintenance. Stroke length and stroke speed can be manually adjusted and standard priming without removing tubing makes it easy to put into operation.

**Aquatrol ChemDose Chemical Dosing Pumps** give you the flexibility to dose from 6gpd to 38gpd with one single pump. This offers greater versatility and convenience for a broad range of applications and puts you in control of your product applications with one single unit.



# ADP SERIES

## CHEMDOSE CHEMICAL DOSING PUMPS

### PUMP SPECIFICATIONS

- Max. Capacity: 38 GPD (144 LPD)
- Pressure: 72.5 Psi (5 BAR)
- Power: 40 W
- Voltage: 110V or 220 V
- Hertz: 50/60 Hz
- Flow: 1.6 gal/h (6 L/h)
- Max. Temperature: 104 °F (40 °C)
- Stroke per minute: 180
- Suction: 2 m
- IP55 protection
- Anticorrosive plastic casing
- Manual stroke frequency control
- Product Weight: 4.85 lbs (2.2 kg)

### MATERIALS OF CONSTRUCTION

#### LIQUID ENDS MATERIALS:

- Diaphragm : TEFLON
- Pump head: PVC, PP, SS316, PTFE
- Suction and the delivery valve: PVC, PP, SS316, PTFE
- Filter: PP
- Injection valve: PP (G1/2")
- Suction tube: PVC, PE, PTFE
- Delivery tube: PVC, PE, PTFE
- Seals: FPM

### CHEMICAL COMPATIBILITY

The pump should be used to dose the liquid which has been expressly designed to dose. Chemical compatibility of this pump with the following solutions is rated as good. For chemicals not listed, please contact your local representative or the factory.

- |  |                            |
|--|----------------------------|
| » Alum                                 | » Calcium Hypochlorite     |
| » Muriatic Acid (5% Hydrochloric Acid) | » Polyphosphates           |
| » Potassium Permanganate, 10%          | » Sodium Bicarbonate       |
| » Sodium Carbonate                     | » Sodium Hydroxide         |
| » Sodium Hypochlorite                  | » Sodium Hexametaphosphate |
| » Sodium Phosphate                     | » Sodium Thiosulfate       |
| » Vinegar                              |                            |

Any other liquids should be confirmed with the manufacturer for suitability before use.

Use of different liquids is considered improper and can represent a danger to the user and equipment. Improper liquids can damage the pump material can damage the pump or the operator. Aquatrol can help the user select the pump according to the characteristics of the liquid.

*Aquatrol will not be held responsible for damage deriving from improper use of the pump.*

### PUMP DIMENSIONS

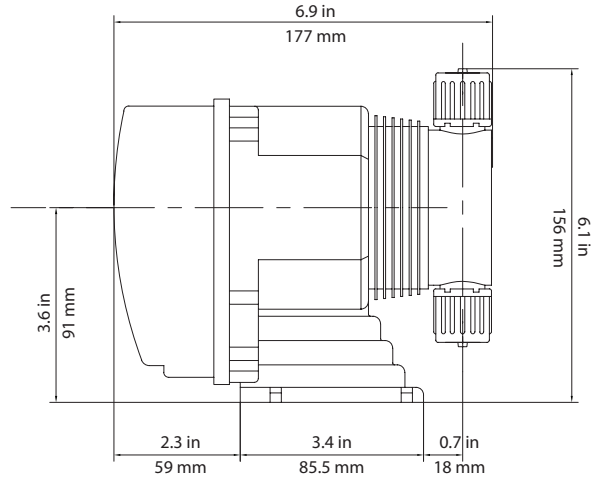

SIDE

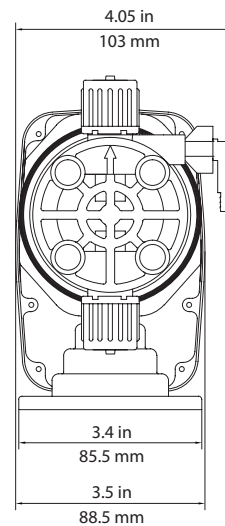

BACK

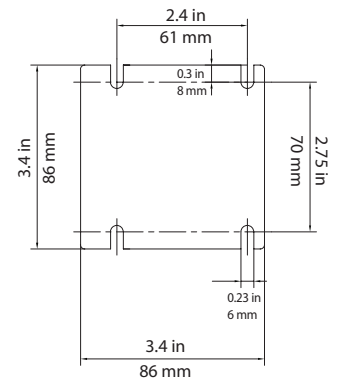

BASE

LIT-ADP-DS 12/20/18



AQUATROL | P.O. Box 2235 Chino Hills, CA 91709 • USA

Distributed by: