



FEATURES

Impeller: Cast iron, ASTM A48, Class 30, two vane semi-open, non-clog design with pump out vanes for mechanical seal protection. Balanced for smooth operation. Silicon bronze impeller is an option.

Casing: Heavy duty gray cast iron, ASTM A48, Class 30. Volute type casing with 3", 125#, ANSI flanged, horizontal discharge. Compatible with A10-30 cast iron or A10-30B cast iron and brass (non-sparking) guide rail assembly.

Dual Mechanical Seals: Silicon carbide vs. silicon carbide outer seal and ceramic vs. carbon inner seal, stainless steel metal parts, BUNA-N elastomers. Upper and lower shaft seals are positioned independently and are separated by an oil-filled chamber.

Shaft: 300 series stainless steel keyed design.

Fasteners: 300 series stainless steel.

Capable of running dry temporarily without damage to seals or motor.

WS_D3 Series

Model 3888D3

SUBMERSIBLE SEWAGE PUMPS

Wastewater

APPLICATIONS

Used in a variety of residential, commercial and industrial applications such as:

- Sewage systems, Flood and Pollution Control, Dewatering/Effluent, Farms, Hospitals, Trailer Courts, Motels

SPECIFICATIONS

Pump:

- Maximum solid size: 2.5"
- Discharge size: 3", 125 # ANSI flange
- Maximum capacity: 470 GPM
- Maximum total head: 65 feet
- 300 Series stainless steel fasteners
- 20' Power cord
- Standard silicon carbide/silicon carbide outer seal

Motor:

- Maximum ambient temperature: 104° F (40° C) continuous duty, 140° F (60° C) intermittent duty
- Rated for continuous duty when fully submerged
- Insulation: Class F
- 60 Hertz
- Single row ball bearings
- 300 Series stainless steel keyed shaft

Single Phase:

- 1.5 - 5 HP; 208 and 230 volts
- Built-in thermal overloads with automatic reset
- Built-in capacitors

Three Phase:

- 1.5 - 5 HP; 200, 230, 460 and 575 volts
- Class 10 overload protection must be provided in control panel

MOTORS

- Fully submerged in oil-filled chamber: High grade turbine oil surrounds motor for more efficient heat dissipation, permanent lubrication of bearings and mechanical seal for complete protection against outside environment.
- Class F insulation
- Designed for Continuous Operation: Pump ratings are within the motor manufacturer's recommended working limits and can be operated continuously without damage when fully submerged.
- Bearings: Upper and lower heavy duty ball bearing construction for precision positioning of parts and to carry thrust loads.
- Power Cable: Severe duty rated, oil and water resistant. Epoxy seal on motor end provides secondary moisture barrier in case of outer jacket damage and to prevent oil wicking. 20 foot standard with optional lengths available.
- O-ring: Assures positive sealing against contaminants and oil leakage.

AGENCY LISTINGS



Tested to UL 778 and CSA 22.2 108 Standards
By Canadian Standards Association
File #LR38549

MODEL AND MOTOR INFORMATION

Order No.	HP	Phase	Volts	RPM	Impeller Dia. (in.)	Maximum Amps	L.R. Amps	KVA Code	Power Cable	F.L. Motor Efficiency %	Resistance		Wt. (lbs.)	
											Start	Line-Line		
WS1518D3M	1.5	1	208	1750	5.25	15.0	50.8	B	14/3	80	1.1	0.9	192	
WS1512D3M			230			12.5	29.5	E		70	1.4	1.8		
WS1538D3M		3	200			11.5	40.9	H	14/4	81	NA	1.7		190
WS1532D3M			230			10.0	40.0	F		83		2.3		
WS1534D3M			460			5.0	20.0	F		83		9.3		
WS1537D3M			575			4.0	14.4	H		74		14.8		
WS1518D3	1.5	1	208	1750	6.50	15.0	50.8	B	14/3	80	1.1	0.9	192	
WS1512D3			230			12.5	29.5	E		70	1.4	1.8		
WS1538D3		3	200			11.5	40.9	H	14/4	81	NA	1.7		190
WS1532D3			230			10.0	40.0	F		83		2.3		
WS1534D3			460			5.0	20.0	F		83		9.3		
WS1537D3			575			4.0	14.4	H		74		14.8		
WS2018D3	2	1	208	1750	7.00	19.0	50.8	B	14/3	80	1.1	0.9	196	
WS2012D3			230			16.0	36.9	D		75	1.4	1.5		
WS2038D3		3	200			11.5	40.9	H	14/4	81	NA	1.7		194
WS2032D3			230			10.0	40.0	F		83		2.3		
WS2034D3			460			5.0	20.0	F		83		9.3		
WS2037D3			575			4.0	14.4	H		74		14.8		
WS3018D3	3	1	208	1750	7.25	25.5	50.8	B	10/3	80	1.1	0.9	205	
WS3012D3			230			21.5	46.4	C		79	1.0	1.0		
WS3038D3		3	200			15.2	53.8	G	14/4	85	NA	1.3		200
WS3032D3			230			12.0	49.5	H		83		1.9		
WS3034D3			460			6.0	24.8	H		83		7.5		
WS3037D3			575			4.8	17.3	G		78		11.6		
WS5012D3	5	1	230	1750	8.00	26.5	57.7	A	10/3	80	1.0	0.8	210	
WS5038D3			200			18.8	73.9	F		84	0.9			
WS5032D3		3	230			16.4	63.6	E	14/4	85	NA	1.2		205
WS5034D3			460			8.2	31.8	E		85		4.8		
WS5037D3			575			6.8	22.8	E		80		7.4		

MATERIALS OF CONSTRUCTION

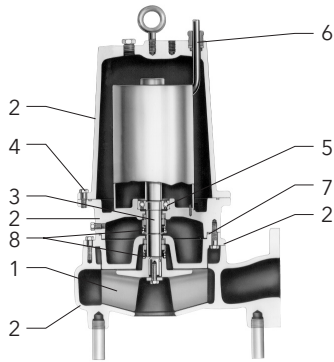

Item No.	Part Name	Material				
		Standard	Optional			
1	Impeller, non-clog	1003	1179			
2	Castings	1003				
3	Shaft-keyed	300 Series SS				
4	Fasteners	300 Series SS				
5	Ball bearings	Steel				
6	Power cable	STOW, 20 feet			Additional lengths	
7	O-ring	BUNA-N				
8	Outer Mech. Seal	Service	Rotary	Stationary	Elastomers	Metal Parts
	OPT	Heavy duty	Silicon Carbide	Tungsten Carbide	BUNA-N	300 Series SS
	STD	Mild abrasives	Silicon carbide		BUNA-N	300 Series SS
Material Code		Engineering Standard				
1003		Cast iron – ASTM A48 Class 30				
1179		Silicon bronze – ASTM C87600				

PERFORMANCE RATINGS (gallons per minute)

Series No. ▶	WS15D3M	WS15D3	WS20D3	WS30D3	WS50D3
HP ▶	1½	1½	2	3	5
RPM ▶	1750				
Total Head Feet of Water	10	160	300		
	15	90	260	320	
	20		210	280	350
	25		160	235	310
	30		100	185	265
	35			130	210
	40			60	160
	45				100
	50				
	55				
	60				

METERS FEET

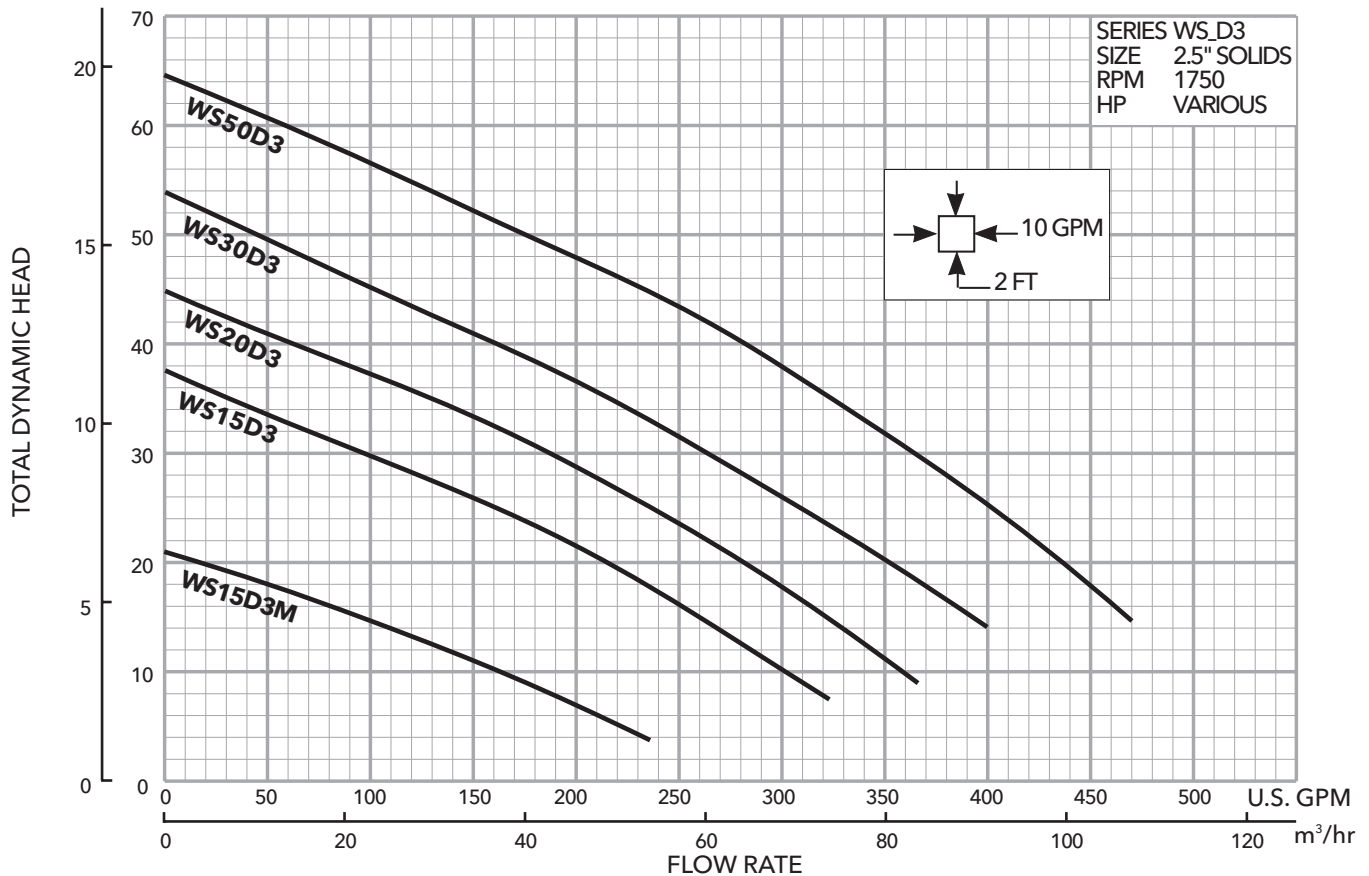

APPLICATION DATA AND CONSTRUCTION DETAILS

Maximum Solid Size	2.5"	
Minimum Casing Thickness	5/16"	
Casing Corrosion Allowance	1/8"	
Maximum Working Pressure	30 PSI	
Maximum Submergence	50 feet	
Minimum Submergence	Fully submerged for continuous operation	
	6" below top of motor for intermittent operation	
Maximum Environmental Temperature	40° C (104° F) continuous operation, 60° C (140° F) intermittent operation	
Power Cable - Type (See Motor Information for AWG data/size.)	Type SJTOW: single phase, 1½ and 2 HP	
	Type STOW: single phase, 1½ - 3 HP and 5 HP, 460 V	
	Type STOW: single phase, 3 and 5 HP, three phase 5 HP, 230 V	
Motor Cover, Bearing Housing, Seal Housing, Casing	Gray Cast Iron - ASTM A48, Class 30	
Impeller - Standard, Optional	Gray Cast Iron - ASTM A48 or Cast Bronze - ASTM B584 C87600	
Motor Shaft	AISI 300 Series Stainless Steel	
Motor Design	NEMA 56 Frame, oil filled with Class F Insulation	
Motor Overload Protection	Single phase: on winding thermal overload protection auto reset	
	Three phase: requires Class 10 overloads in control panel	
External Hardware	300 Series Stainless Steel	
Impeller Type	Semi-open with pump out vanes on back shroud	
Oil Capacity - Seal Chamber	1.5 quarts	
Oil Capacity - Motor Chamber	1½-5 HP single and three phase: 7 quarts	
Mechanical Seals - Standard	Upper	Carbon/Ceramic; Type 21
	Lower	Silicon Carbide/Silicon Carbide; Type 31
Mechanical Seals - Optional Lower	Silicon Carbide/Tungsten Carbide; Type 31	

DIMENSIONS

(All dimensions are in inches. Do not use for construction purposes.)

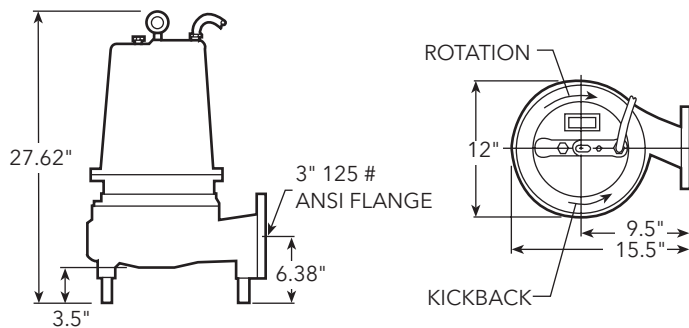

xylem
Let's Solve Water

Xylem, Inc.
2881 East Bayard Street Ext., Suite A
Seneca Falls, NY 13148
Phone: (866) 325-4210
Fax: (888) 322-5877
www.xyleminc.com/brands/gouldswatertechology

Goulds is a registered trademark of Goulds Pumps, Inc. and is used under license.
SKF is a registered trademark of Aktiebolaget SKF, Sweden.
© 2012 Xylem Inc. B3888D3 R1 April 2012