



**FEATURES**

**Impeller:** Cast iron, enclosed, non-clog, dynamically balanced with pump out vanes for mechanical seal protection.

**Casing:** Cast iron flanged volute type for maximum efficiency. Designed for easy installation on A10-20 slide rail or base elbow rail systems.

**Mechanical Seal:** SILICON CARBIDE VS. SILICON CARBIDE sealing faces for superior abrasive resistance, stainless steel metal parts, BUNA-N elastomers.

**Shaft:** Corrosion-resistant, 300 series stainless steel. Threaded design. Locknut on all models to guard against component damage on accidental reverse rotation.

**Fasteners:** 300 series stainless steel.

Capable of running dry without damage to components.

Designed for continuous operation when fully submerged.

**EXTENDED WARRANTY AVAILABLE FOR RESIDENTIAL APPLICATIONS.**

# WS\_BHF Series

## Model 3887BHF

SUBMERSIBLE SEWAGE PUMP

### APPLICATIONS

Specifically designed for the following uses:

- Homes
- Sewage systems
- Dewatering/Effluent
- Water transfer
- Light industrial
- Commercial applications

Anywhere waste or drainage must be disposed of quickly, quietly and efficiently.

### SPECIFICATIONS

#### Pump

- Solids handling capabilities: 2" maximum
- Capacities: up to 220 GPM
- Total heads: up to 81 feet TDH
- Discharge size: 2" NPT threaded companion flange as standard. 3" option available but must be ordered separately. (Order no. A1-3)
- Temperature: 104°F (40°C) continuous  
140°F (60°C) intermittent.

#### MOTORS

- Fully submerged in high grade turbine oil for lubrication and efficient heat transfer. All ratings are within the working limits of the motor.

Class B insulation on 1/3-1 1/2 HP models.

Class F insulation on 2 HP models.

#### Single phase (60 Hz):

- Capacitor start motors for maximum starting torque.
- Built-in overload with automatic reset.
- SJTOW or STOW severe duty oil and water resistant power cords.
- 1/3 - 1 HP models have NEMA three prong grounding plugs.
- 1 1/2 HP and larger units have bare lead cord ends.

#### Three phase (60 Hz):

- Class 10 overload protection must be provided in separately ordered starter unit.
- STOW power cords all have bare lead cord ends.
- Bearings: Upper and lower heavy duty ball bearing construction.
- Designed for Continuous Operation: Pump ratings are within the motor manufacturer's recommended working limits, can be operated continuously without damage when fully submerged.
- Power Cable: Severe duty rated, oil and water resistant. Epoxy seal on motor end provides secondary moisture barrier in case of outer jacket damage and to prevent oil wicking. Standard cord is 20'. Optional lengths are available.
- Motor Cover O-ring: Assures positive sealing against contaminants and oil leakage.

#### AGENCY LISTINGS



Tested to UL 778 and CSA 22.2 108 Standards  
By Canadian Standards Association  
File #LR38549

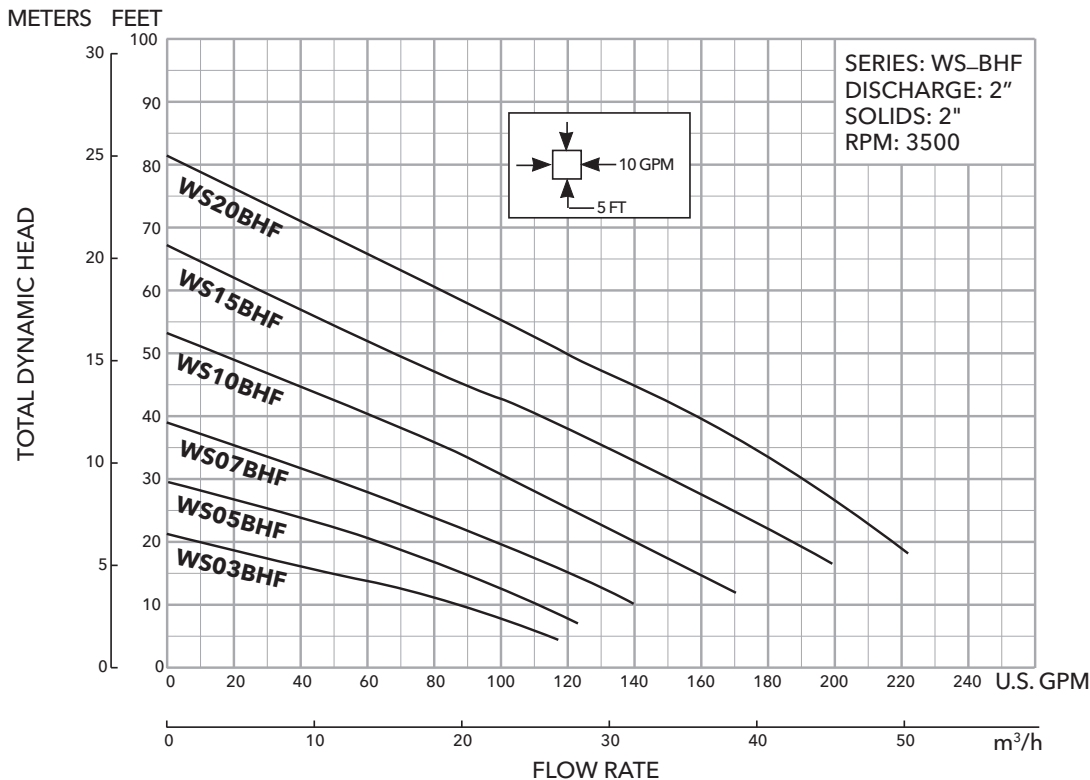

### MOTOR AND MODEL INFORMATION

Order Number	HP	Phase	Volts	RPM	Impeller Dia. (In.)	Max. Amps	Locked Rotor Amps	KVA Code	Full Load Motor Eff. %	Resistance		
										Start	Line-Line	
WS0311BHF	0.33	1	115	3500	2.94	12.4	46.0	M	54	7.5	1.0	
WS0318BHF	0.33	1	208			6.8	31.0	K	68	9.7	2.4	
WS0312BHF	0.33	1	230			6.2	34.5	M	53	9.6	4.0	
WS0511BHF	0.5	1	115		3.19	14.5	46.0	M	54	7.5	1.0	
WS0518BHF	0.5	1	208			8.4	31.0	K	68	9.7	2.4	
WS0512BHF	0.5	1	230			7.6	34.5	M	53	9.6	4.0	
WS0538BHF	0.5	3	200			4.9	22.6	R	68	-	3.8	
WS0532BHF	0.5	3	230			3.6	18.8	R	70	-	5.8	
WS0534BHF	0.5	3	460			1.8	9.4	R	70	-	23.2	
WS0537BHF	0.5	3	575			1.5	7.5	R	62	-	35.3	
WS0718BHF	0.75	1	208			3.44	11.0	31.0	K	68	9.7	2.4
WS0712BHF	0.75	1	230				10.0	27.5	J	65	12.2	2.7
WS0738BHF	0.75	3	200				6.2	20.6	L	64	-	5.7
WS0732BHF	0.75	3	230				5.4	15.7	K	68	-	8.6
WS0734BHF	0.75	3	460				2.7	7.9	K	68	-	34.2
WS0737BHF	0.75	3	575		2.2		9.9	L	78	-	26.5	
WS1018BHF	1	1	208		3.75	14.5	59.0	K	68	9.3	1.1	
WS1012BHF	1	1	230			13.0	36.2	J	69	10.3	2.1	
WS1038BHF	1	3	200			8.6	27.6	M	77	-	2.7	
WS1032BHF	1	3	230			7.5	24.1	L	79	-	4.1	
WS1034BHF	1	3	460			3.8	12.1	L	79	-	16.2	
WS1037BHF	1	3	575			3.1	9.9	L	78	-	26.5	
WS1512BHF	1.5	1	230		4.00	18.0	52.0	J	67	2.76	0.53	
WS1538BHF	1.5	3	200			10.0	42.4	K	78	-	1.7	
WS1532BHF	1.5	3	230			9.6	42.4	K	78	-	1.7	
WS1534BHF	1.5	3	460			4.8	21.2	K	78	-	6.6	
WS1537BHF	1.5	3	575			3.9	16.3	L	78	-	10.5	
WS2012BHF	2	1	230		4.44	18.0	49.6	F	78	3.2	1.1	
WS2038BHF	2	3	200			12.0	42.4	K	78	-	1.7	
WS2032BHF	2	3	230			11.6	42.4	K	78	-	1.7	
WS2034BHF	2	3	460	5.8		21.2	K	78	-	6.6		
WS2037BHF	2	3	575	4.7		16.3	L	78	-	10.5		

### DIMENSIONS

(All dimensions are in inches. Do not use for construction purposes.)

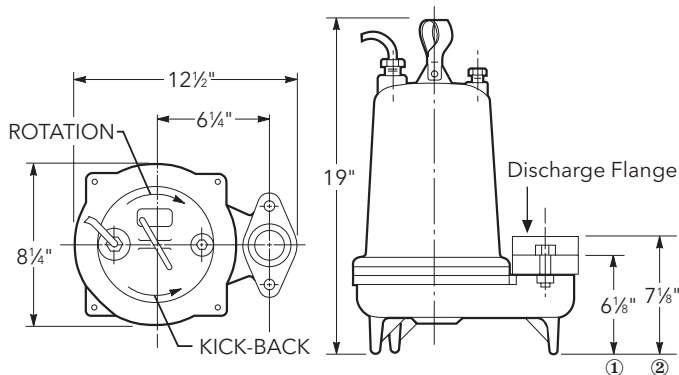

#### Discharge Flange:

- ① 2" NPT standard
- ② 3" NPT optional (order an A1-3)

**PERFORMANCE RATINGS** (gallons per minute)

Order No.	WS03-BHF	WS05-BHF	WS07-BHF	WS10-BHF	WS15-BHF	WS20-BHF
	HP	1/3	1/2	3/4	1	1 1/2
RPM	3500	3500	3500	3500	3500	3500
10	86	110	140	-	-	-
15	48	88	120	158	-	-
20	-	62	98	139	186	217
25	-	32	74	120	170	204
30	-	-	49	101	150	190
35	-	-	21	82	130	175
40	-	-	-	60	110	159
45	-	-	-	38	88	140
50	-	-	-	-	67	120
55	-	-	-	-	47	100
60	-	-	-	-	29	80
65	-	-	-	-	-	62
70	-	-	-	-	-	43
75	-	-	-	-	-	23

**COMPONENTS** (for reference only)

Item No.	Description
1	Impeller
2	Casing
3	Mechanical Seal
4	Motor Shaft
5	Motor
6	Ball Bearings
7	Power Cable
8	Casing O-Ring

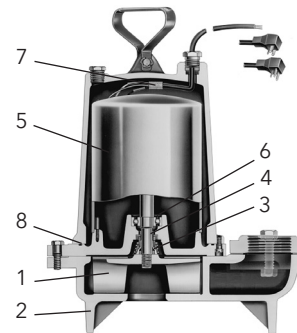

**\* For repair parts, reference repair parts book.**